



Dorood Kelid Electric Company

Composite Insulators





About Us

Dorood Kelid Electric Co is one of the leaders in producing electrical equipment with more than 30 years of experience. Dorood Kelid Electric Co is now proud to announce the production of composite insulators of up to 400kV for the first time in Iran. Our belief is to respect the international standards; hence, Dorood Kelid Electric Co has coordinated with various international companies and national experts for over two years in order to optimize the quality of its products. In line with this trend, Dorood Kelid Electric Co has benefited from the latest technologies and innovations of leading research institutions such as NRI, STRI, and EPRI among others.

Our products are standardized, as demonstrated in the insulator's characteristics section. Resistance maximisation of the rods, high resistance fittings, reduction in the electrical field, minimised partial discharge are just a few of the characteristics of the insulators that highlight the innovative and cutting-edge technology used in Dorood Kelid Electric Co's product range.

Combining our 30 years of experience with the innovative technology has provided us an exceptional opportunity to produce insulators with unique features, which we strongly believe, will provide us with the opportunity to supply our products globally and play a major role in the international market. Our high quality and low prices will enable us to compete with international companies in the field of electrical equipment production.

Our aim is to gain customer confidence and satisfaction. In order to accomplish our aim, shareholders of Dorood Kelid Electric Co attempt to equip themselves with latest industry knowledge and technology.

Introduction

Insulators are one of the causal components in transmission and distribution of energy. They are installed between conductor and tower to secure electrical and support conductor's lines. DK electric's technology and experience that produce high quality silicon insulators have made us one of the best manufacturers in the region.

Characteristics of composite insulators

The rods utilized in producing insulators of this company are of ECR which possess a high degree of resistance confronting the process of erosion and are anti Acid.

The utilized compound is a combination of the best type of Silicone and high quality filler which protects the cover of the insulator against harsh environment such as U.V, Ozone, acids, pollution and humidity.

Fittings are produced under the forge method.

The design of the insulators' sheds is appropriate for different regions with various climates especially regions with heavy pollution; this process is according to standards such as IEC60815.

Fittings are assembled with the method of crimping with high level of assurance and they have passed quality tests.

Modern and developed machinery and equipment are used for crimping, with the possibility of examining the quality of the crimping process (by using Sonar sensors).

The design of the Corona ring is done by accurate digital assimilation in order to reduce and to balance the electrical field around and on the insulator's sheds. In order to optimize the sheds and dimensional characteristics of different parts of the insulator the most recent findings of the research institutions such as EPRI, STRI, and NRI and others are considered.

The Corona ring is made of aluminium which is resistant against harsh weather conditions; it is polished for the reasons of reducing Corona and partial discharge. The utilized bolts and arms in Corona ring all are made of stainless steel in order to be anti-corrosion.

It is considered some projections on Corona ring and fitting to lock Corona ring on fitting (to prevent movement in service). This helps to convenience and fast installation.

The special design of the Corona ring makes impossible any inaccuracy in its installation.

In order to maximize the resistance of the insulator's rod against humidity and pollution, the thickness of the sheath on the rod is between 3-4mm. In order to maximize the sealing of the rod against humidity, the fitting is covered with Silicone. Moreover, in order to maximize the assurance of the sealing two grooves are considered in the design of the fittings which are filled by Silicone. In order to increase the resistance against absorption in the part of sealing, different parallel methods are used; the reason is to prevent any deficiency such as break of the rod which is one of the most common and dangerous deficiencies of insulators.

Simulation method is used in designing the insulator's sheds and sealing, this method is utilized in order to decrease the electrical field on the sheath and sheds and consequently increasing the age of the insulator. As a result of the decrease of the electrical field on the surface of the sheath and sheds, the partial discharge on the Silicone is minimized; this prevents the tracking and erosion of the surface and the water slip.

The special design of the company's insulators is in a way that does not require Corona ring up to 400 KV, which is, however, possible to install Corona ring in this rate of voltage upon the request of the consumer.

During the producing process, quality control is performed and finally routine tests are executed on the production.



SILICONE POLYMER INSULATOR

Material Preparation

Fiberglass Reinforced Plastic Rods (ECR)



Cut to appropriate length



Surface treatment
Primer Coating

Silicon Rubber



Hardware



Assembly



* Superior crimping of rod by hardware using an exclusive multi-step pressure controlled process
* Excellent water-tight sealing prevents moisture ingress to the core.

Various shed profiles and ECR core sizes

Various combinations of shed profiles and ECR rod sizes are chosen according to the application voltages, leakage distances, and required electrical and mechanical performance. We have selected our shed profiles through extensive research including many artificial pollution tests and field tests with customers.

MANUFACTURING PROCESS

Routine Tests & Assembly

Routine Tests



Routine tensile proof test
Every insulator is subjected to test according to IEC standards

Injection



Injection & Transfer Moulding

- * No joint is required for mould of the insulators
- * Chemical bonding between rubber and ECR rod is stronger than rubber's tear strength
- * Direct one-piece moulding creates no interface between sheaths and sheds.

Packing



After the visual inspection, insulators are carefully packed according to the customer specifications.



Silicone Rubber Characteristics

Silicon rubber is a peroxide curing, high consistency silicone rubber that crosslinks under elevated temperature to an elastomer of high hardness. Silicone rubber provides excellent electrical properties especially suitable for outdoor use in the Transmission and Distribution applications. Furthermore there are some special characteristics of Silicone rubber such as:

- High tracking and arcing resistance
- Excellent hydrophobicity
- Very good dielectric properties

A Variety of Polymer Insulators



Catalog Numbering System

TYPE OF INSULATOR	SML (kN)	SECTION LENGTH (mm)	TOWER END FITTING	LINE END FITTING	SPECIFIC CREEPAGE DISTANCE (mm)	CORONA RING
TS: Tension Suspension SP: Spacer PT: Pine Type	70 120 160 210	Section Length of Insulator in millimeter	S: Socket Y: Y Clevis C: Clevis E: Oval Eye T: Tongue B: Ball CL: Clamp PTF: Pin Type Fitting	B: Ball S: Socket Y: Y Clevis C: Clevis E: Oval Eye T: Tongue CL: Clamp PTF: Pin Type Fitting	Specific Creepage Distance of Insulator rounded to the nearest millimeter	X: (Both Ends) Y: (Line End) Z: (Optional: Line End) N: None

Sample Number: TS-210-4690-SB-37-X

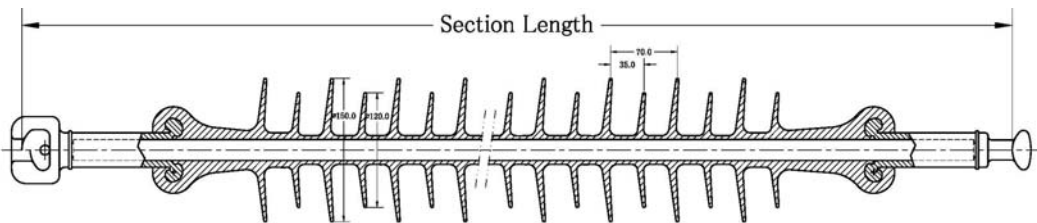

All Dimensions are in Millimeter

Catalog Number	Ur	Specified Mechanical Load	Section Length	Creepage Distance	Arcing Distance	Lightning Impulse Withstand Voltage ≥		Power Frequency Withstand Voltage ≥	
	KV					KN	mm	mm	mm
TS-70-422-CT-26-N	24	70	422	634	328	125	135	50	50
TS-70-433-CT-28-N	24	70	433	680	310	200	215	60	60
TS-70-433-SB-28-N	24	70	433	680	310	200	215	60	60
TS-70-477-CB-32-N	24	70	477	772	340	230	230	65	65
PT-13.4-292-PTF-23-N	24	13.4	292	550	217	125	140	50	50
PT-13.4-300-PTF-23-N	24	13.4	300	550	225	155	170	55	55
PT-13.4-360-CT-32-N	24	13.4	360	765	285	170	185	70	70
TS-70-603-CT-28-N	36	70	603	1015	476	170	188	70	70
TS-70-603-CT-32-N	36	70	603	1140	470	260	275	80	70
TS-70-603-SB-32-N	36	70	603	1140	470	260	275	80	70
PT-13.4-355-PTF-22-N	36	13.4	355	780	277	170	188	70	70
PT-13.4-420-PTF-28-N	36	13.4	420	1000	370	230	245	75	75
PT-13.4-450-PTF-29-N	36	13.4	450	1051	380	230	245	75	75
TS-120-956-SB-33-N	63	120	956	2341	846	500	520	230	195
TS-120-1000-SB-36-N	63	120	1000	2624	950	530	540	250	220
TS-120-1095-SB-40-N	63	120	1095	2870	1020	555	690	290	266
TS-160-1375-SB-25-Z	132	160	1375	3590	1170	570	585	390	300
TS-160-1655-SB-32-Z	132	160	1655	4591	1450	700	720	460	340
TS-160-1800-SB-36-Z	132	160	1800	5145	1595	750	765	510	440
TS-160-2000-SB-41-Z	132	160	2000	5873	1805	850	875	520	445
TS-210-2100-SB-42-Z	132	160	2100	6091	1870	860	880	530	450
TS-210-2100-SB-25-Y	230	210	2100	6091	1870	860	880	530	450
TS-210-2590-SB-32-Y	230	210	2590	7871	2360	1100	1135	620	560
TS-210-2800-SB-35-Y	230	210	2800	8631	2570	1210	1240	650	590
TS-210-3150-SB-41-Y	230	210	3150	9914	3130	1520	1670	715	650
TS-210-3355-SB-44-X	230	210	3355	10671	3125	1520	1560	820	650
TS-210-3355-SB-25-X	400	210	3355	10671	3125	1520	1560	820	650
TS-210-4200-SB-33-X	400	210	4200	13733	3970	1850	1900	980	790
TS-210-4690-SB-37-X	400	210	4690	15506	4460	2100	2150	1050	860
TS-210-5170-SB-41-X	400	210	5170	17300	4950	2330	2365	1160	955

Phase to Phase Spacer



TECHNICAL DATA			
Ur	KV	24	36
Specified Mechanical Load	KN	70	70
Section Length	mm	840	1100
Creepage Distance	mm	1100	1360
Arcing Distance	mm	716	976
Lightning Impulse Withstand Voltage \geq	Pos.	333	360
	Neg.	348	370
Power Frequency Withstand Voltage \geq	Dry	190	240
	Wet	181	230

Transformer Bushing Cover

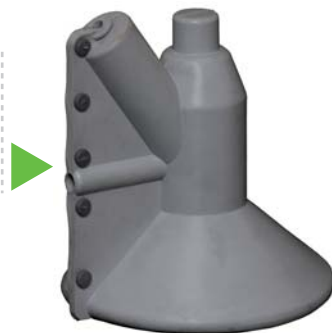

24 & 36KV Silicon Robber Rod Insulator



Polymeric Insulator For Outdoor Terminations



High Voltage Fittings

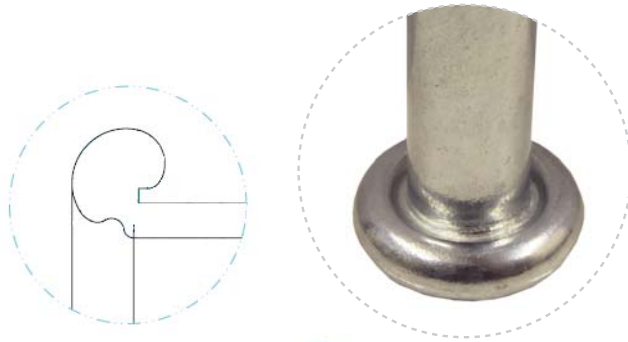

In order to maximize the assurance of the sealing, two grooves are considered in the design of the fittings which are filled by silicone.

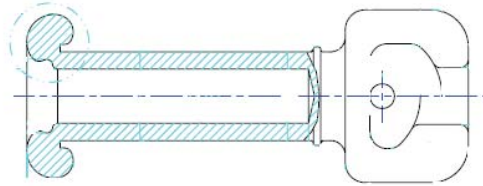

All fittings are produced under the forge method. Fittings are assembled with the method of crimping with high level of assurance and they have passed quality tests. Modern and developed machinery and equipment are used for crimping, with the possibility of examining the quality of the crimping process (by using Sonar sensors).

Meddium Voltage Fittings



Recommended Corona Ring Application

Rated voltage	132 kV	230 kV	400 kV
Line end	NO	YES	YES
Ground end	NO	NO	YES
Part number suffix	Z	Y	X

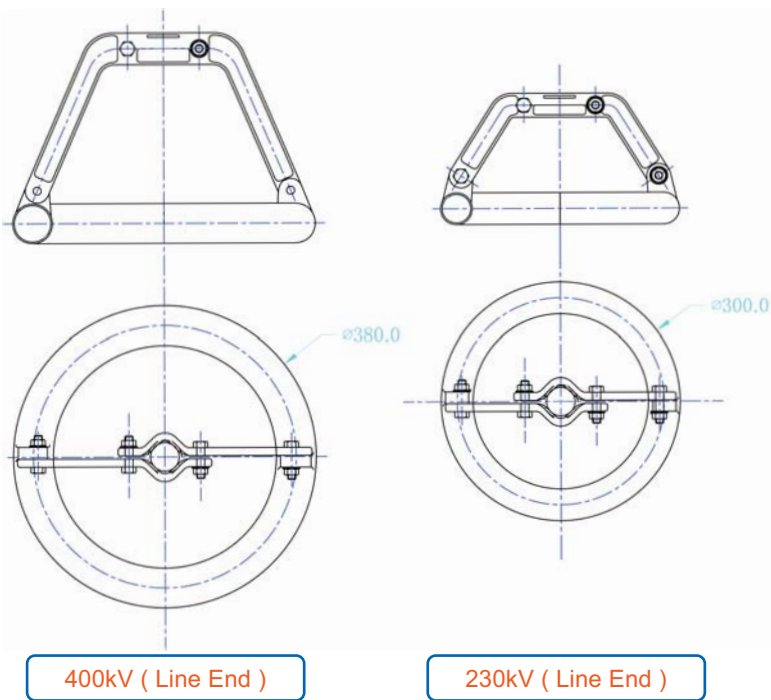

400kV (Line End)

230kV (Line End)

The design of the Corona ring is done by accurate digital assimilation in order to reduce and to balance the electrical field around and on the insulator's sheds. The Corona ring is made of aluminum which is resistant against harsh weather conditions; it is polished for the reasons of reducing Corona and partial discharge. The utilized bolts and arms in Corona ring all are made of stainless steel in order to be anti-corrosion.

The special design of the Corona ring makes impossible any inaccuracy in its installation.

The special design of the company's insulators is in a way that does not require Corona ring up to 132 KV, which is, however, possible to install Corona ring in this rate of Voltage upon the request of the consumer.



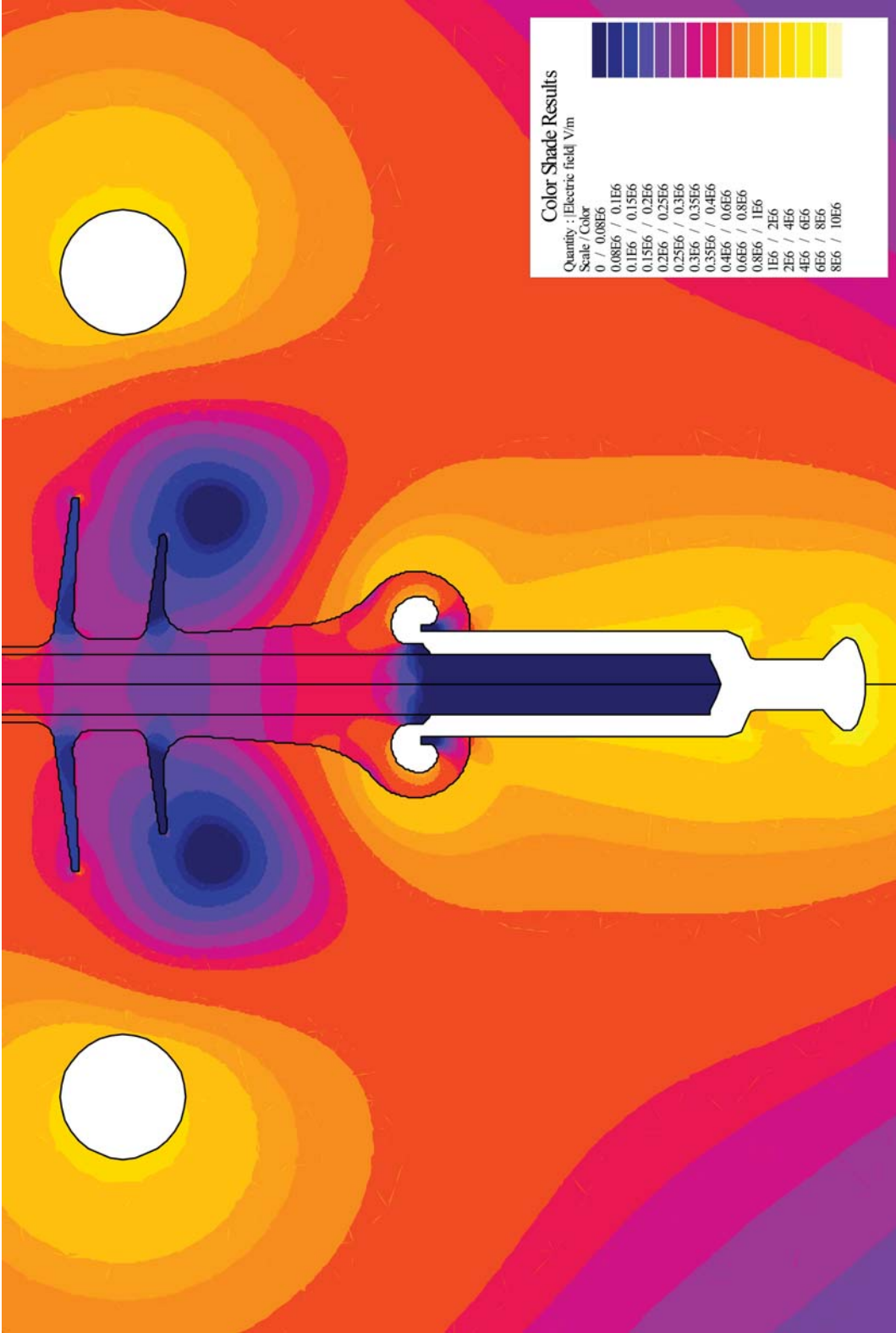

Simulation method is used in designing the insulator's sheds and sealing. This method is utilized in order to decrease the electrical field on the sheath and sheds and consequently increases the age of the insulator. As a result of decreasing the electrical field on the surface of the sheath and the sheds, the partial discharge on the silicone is minimized; this prevents the tracking and the erosion of the surface and the water slip.

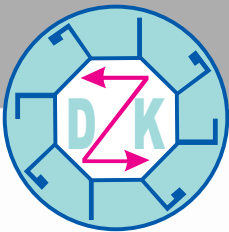
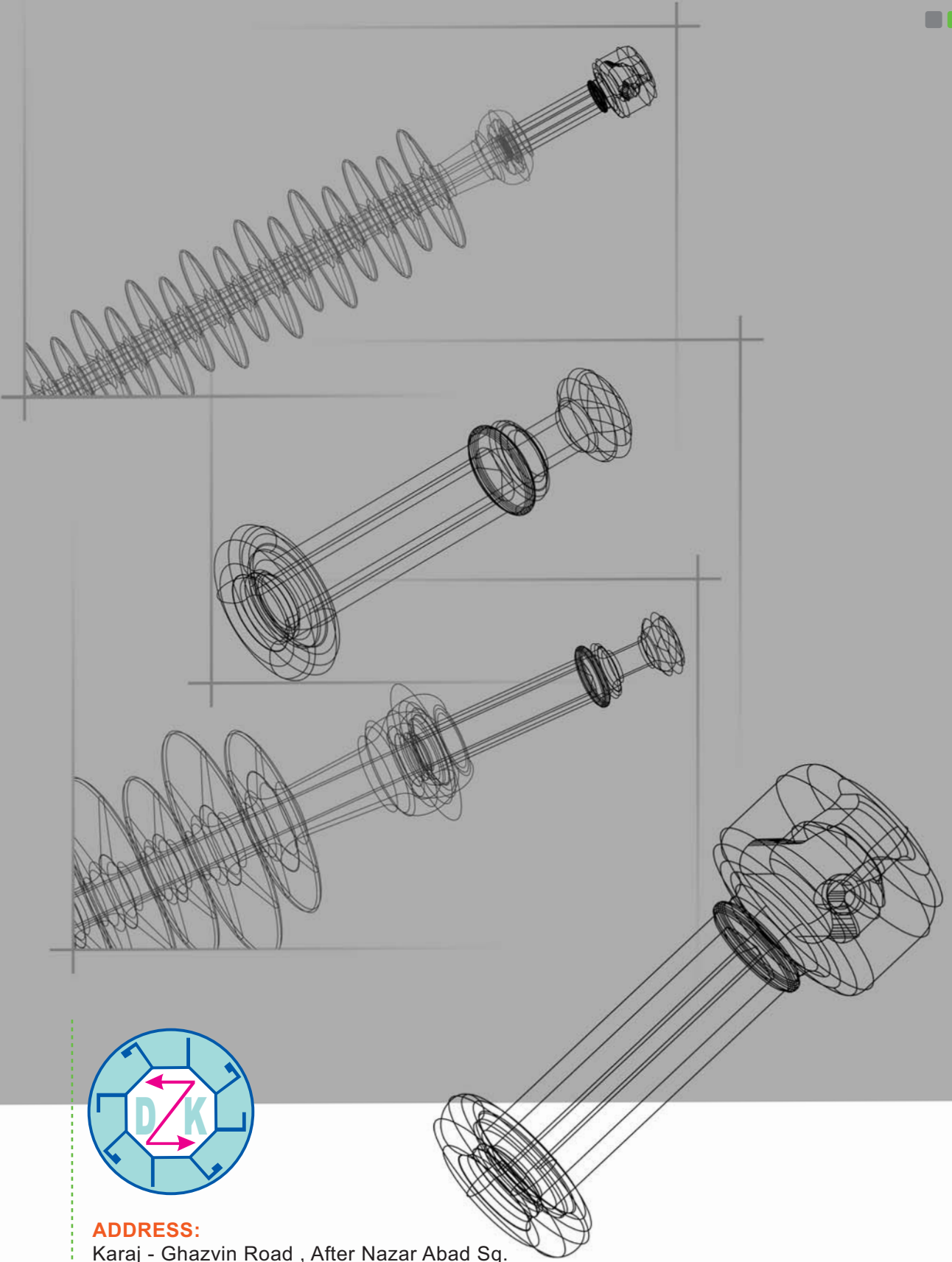

ADDRESS:

Karaj - Ghazvin Road , After Nazar Abad Sq.

Tel: (+98 264) 5382153 - 6

Fax: (+98 264) 5382156

info@dk-electric.com / Web Site : www.dk-electric.com